

△ OPEN-DECK CONSTRUCTION

# TRAIL KING



# TKHT

HYDRAULIC TAIL



### Zinc-Coated Hinge

Upper deck ramp hinge now bolted in and zinc coated.

## STANDARD FEATURES



### Front Access Panel

Front access panel offers easy access for hydraulic, air, and electrical lines. The zinc-coated panel may be opened for internal maintenance by removing four bolts.



### Simplified Operation

Lighted, push/pull hydraulic controls (on both sides of neck) and remote (winch only). Optional full function remote (shown) offers 2-speed operation. Slow speed function improves maneuverability.



### Upper Deck Ramp

10' hydraulic, recessed ramp at an 11 degree load angle. A locking mechanism ensures that the upper deck ramp stays in place during loading.



### Winch, Roller & Skid Plate

20,000-lb. winch & 9/16" cable with winch guard and 80' cable with locking safety hook. A skid plate is standard, or opt for a roller (right).



### Side-Access Toolboxes

Two side-access toolboxes at front of upper deck with chrome T-handles and aluminum floor for corrosion resistance. Option for top access with gas shock and/or interior lighting.



### Aluminum Valve Cover

Protective panel on the underside of the gooseneck shields hydraulic valving.



# **TRAIL KING** **HYDRAULIC TAIL**



## **LOW LOAD ANGLE** **LOW MAINTENANCE** **HIGH PERFORMANCE**

Reduced load angle (12.5 degrees), improved weight distribution and a redesigned tail make the Trail King Hydraulic Tail your go-to choice. Featuring wider track axles as standard, loading and hauling has never been safer or simpler. The HT offers the most scalability while maintaining dependable load-hauling strength and durability. The TKHT is as light as possible, without sacrificing the rugged strength Trail King is known for.



### **Popular Options**

- Top access toolbox with gas shocks & lighting
- Additional light packages
- Work light packages
- Side access steps
- Tie-down packages
- RTAC compliant (custom only)

Find your nearest rep: [www.TrailKing.com/find-a-rep](http://www.TrailKing.com/find-a-rep)

#LOOKFORTHETRIANGLES



@trailkingind



## Increased Usable Deck

Better weight distribution with increased kingpin distance to last axle.



## LOOKING FOR MORE?

Navigate to [www.trailking.com](http://www.trailking.com), and click on the SOLUTIONS tab. Each product page includes specifications, video, literature, images, services information and our official color card.



## Increased Stability

Wider track axles (additional 9")



## Protected Lines & Electrical

Steel lines under the deck, & JIC fittings & O-ring seals at connection points. Rubber-mounted, shock-proof sealed lights and rubber grommets.



## Flip Tail Lock

Integrated flip tail lock prevents the tail from settling to the ground, even in the event of hydraulic failure.

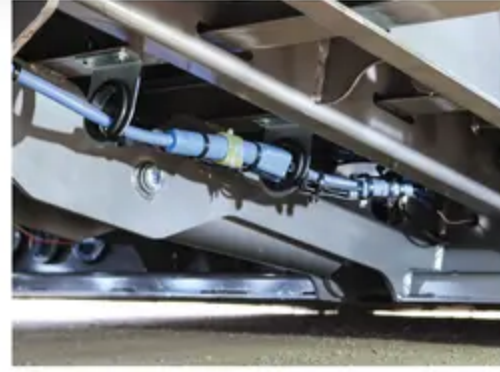

## Ground Clearance

Flip tail linkage bracket and pin have increased ground clearance in loading position.



## Stainless Tail Hinge

Heavy-duty, stainless pins.



## H-bar Transport Lock

One function, integrated, air-operated H-bar assembly and fold under lock provide simple tail operation.



## Reinforced Approach Plate

Two outside beams provide extra strength during loading. The 12 inside beams support the approach plate, providing durability and longevity.

# SIMPLE OPERATION, LOW MAINTENANCE PERFORMANCE

As light as possible, and stronger than ever.

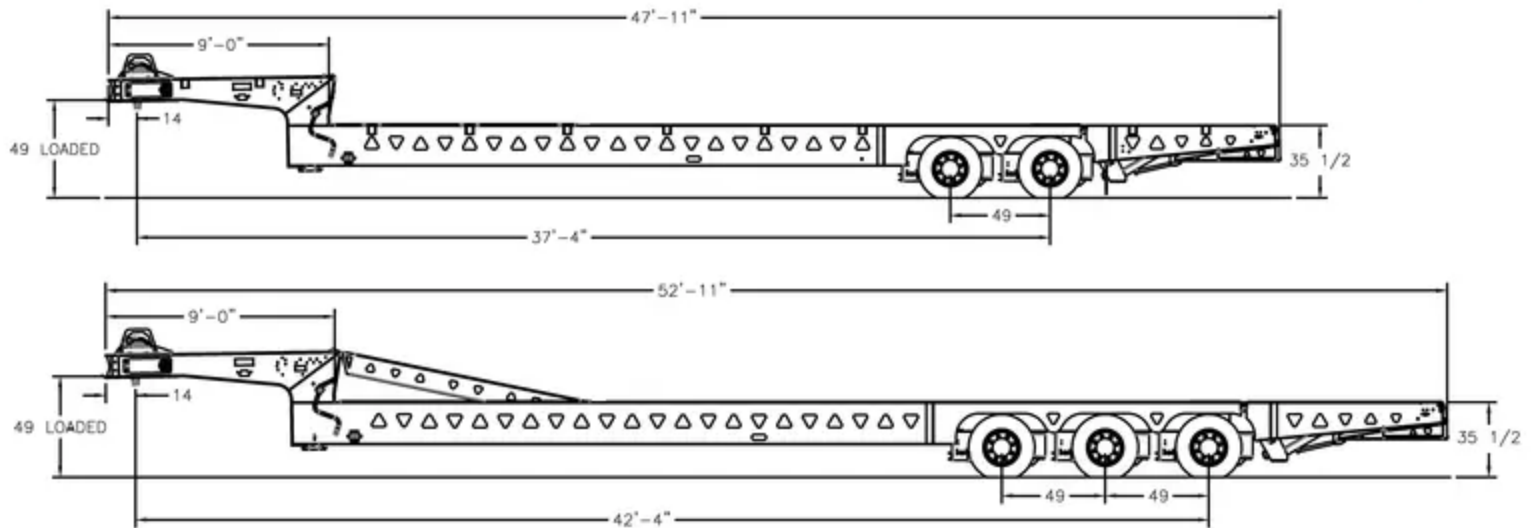

## TK80HT STANDARD EQUIPMENT:

- Capacity: 80K lbs. uniform / 50K lbs. in 10 ft.
- 47' 11" overall length, 102" wide, 49" loaded 5th wheel height
- 14" kingpin setting with 88" swing clearance
- 1/4" floor plate over wheels w/ last 2' Star Traction over 1/4" smooth steel
- Star Traction over 10 ga. smooth steel on deck and fold-under
- 20,000 lb. hydraulic winch with level wind (mounted above kingpin)
- Winch guard
- Wireless remote for winch (1 function, 2 buttons)
- 80' winch cable with locking safety hook
- 10' hydraulic recessed upper deck ramp with ramp locks (11 degrees)
- 12'2" hydraulic tail, 8' main tail with 52" fold-under, 12.5 degree load angle with 245/70R 17.5 tires
- Tail raises to 58" dock height & lowers to the ground
- Heavy duty I-beam style tail hinge beam
- Twelve vertical supports inside fold under
- 1 3/8" (NET) apitong decking (deck/upper deck ramp)
- Air ride raising/lowering with switch on upper deck
- Internal 2-way key slots alternating w/ stake pockets in outer beams approx. 24" on center
- 49" axle spacing
- 25,000 lb. axles (5/8" wall)
- Air ride suspension
- 4S2M ABS brakes
- Automatic slack adjusters
- 6.75 X 17.5 8-hole hub piloted wheels
- One-piece oil seals
- Zip Tork axle nuts
- 245/70R 17.5 - 18 ply radial tires
- Lighted hydraulic valve controls (each side)
- 2 tool boxes at front of upper deck
- 2 speed park stands
- LED lights, 50 state legal
- Electrical system per DOT regulations
- Mid-turn signal clearance lights
- Rubber mounted sealed lights with sealed harness system
- Three tail lights per side (amber in center)
- Red & white conspicuity markings
- Zinc rich primer and polyurethane topcoat
- Mud flaps



# PROTECT YOUR INVESTMENT COMPREHENSIVE SUPPORT UNMATCHED SERVICE



From financing a trailer, to a complete refurbishment at our Factory Service Center, Trail King is there to keep your team hauling, day in and day out. Our trusted network of dealers and certified experts are ready to assist you.

## △ PARTS

**KEEP YOUR TEAM HAULING.** Instantly access over 10,000 on-hand parts and a variety of online tools. All Trail King Certified dealers, fleets, and service facilities can place same-day shipping orders for convenient and efficient ordering. Customers looking for more information can contact a local Trail King dealer or submit direct inquiries to [parts@trailingking.com](mailto:parts@trailingking.com).

## △ REFURB

**PROTECT YOUR INVESTMENT.** Extend the life of your trailer and increase future resale value by restoring it through Trail King's factory refurbishment program. Customers can request a free estimate for comprehensive refurbishments or specified repairs by visiting [trailingking.com/refurb-service](http://trailingking.com/refurb-service). Our expert technicians specialize in Trail King equipment, but we also welcome other trailer brands.

## △ FINANCE

**100% EQUIPMENT FINANCING!** Competitive rates and flexible terms are designed to make a Trail King purchase affordable, convenient, and secure. Trail King's innovative payment program operates with an understanding of the changing demands businesses face. Our full suite of financing structures, including Loans, Finance Leases, and TRAC Leases, makes it easier than ever before to own a Trail King trailer.

## TRAIL KING IS BUILDING SUCCESS.

Trail King Industries, Inc., headquartered in Mitchell, SD, is the leading manufacturer of open deck and materials hauling trailers for the asphalt paving, construction, commercial hauling, agriculture, and specialized transport industries.

Over the years, Trail King has always kept one thing a top priority, our customers' success. Our trailers are customized for unique challenges and together we can create a solution that is just right for your team.

**We don't just build trailers. We design hauling solutions.**

GSA

Sourcewell  
Awarded Contract  
Contract # 092922-TK1



[trailingking.com](http://trailingking.com) / TKHT

300 East Norway Ave. Mitchell, SD 57301 | 800-843-3324 | [trailingking.com](http://trailingking.com)

© 2023 Trail King Industries. All rights reserved.